

Presentation to the Iowa Nuclear Energy Task Force

Michael Wentzel
Division of Advanced Reactors and Non-Power Reactors
Office of Nuclear Reactor Regulation
March 24, 2026

What the NRC Does

- NRC is an independent regulatory agency
- Mission is to protect public health and safety and advance the nation's common defense and security by enabling the safe and secure use and deployment of civilian nuclear energy technologies and radioactive materials through efficient and reliable licensing, oversight, and regulation for the benefit of society and the environment.

The NRC Regulates:

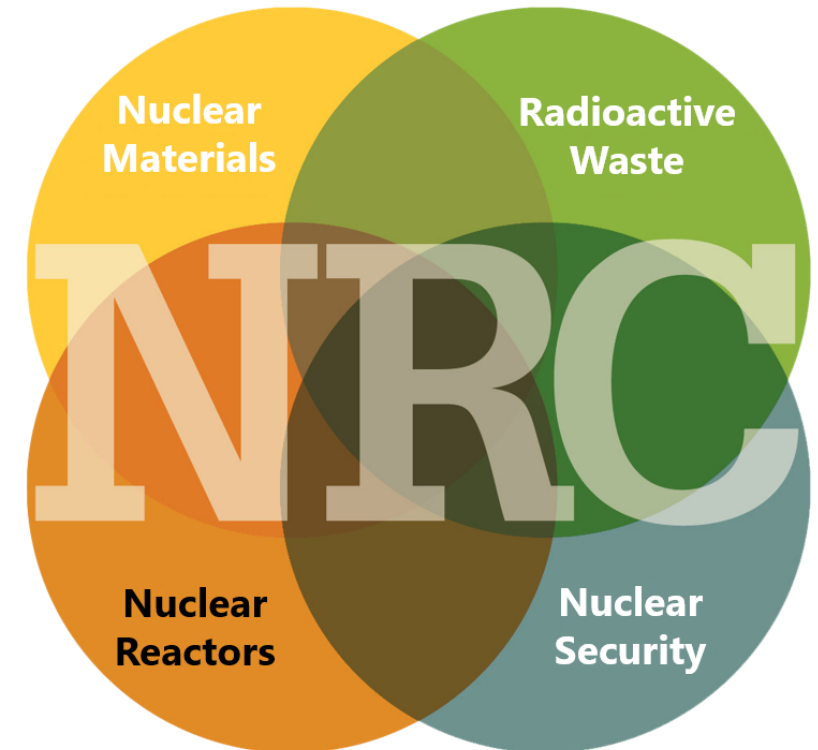

**Streamlined
ACRS and
Hearing
Process**



**Construction
Oversight
Flexibilities**

**Environmental
Reform**



**ADVANCE Act
and
Executive Order
14300**

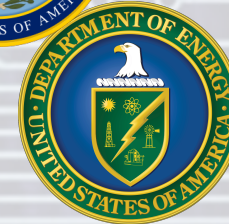

**DOE/DOW
Collaboration**

**Disciplined
Reviews
Focused on
Safety**



**Simplified
Applications**

Advanced Reactor Concepts

Small Modular Reactor (SMR)

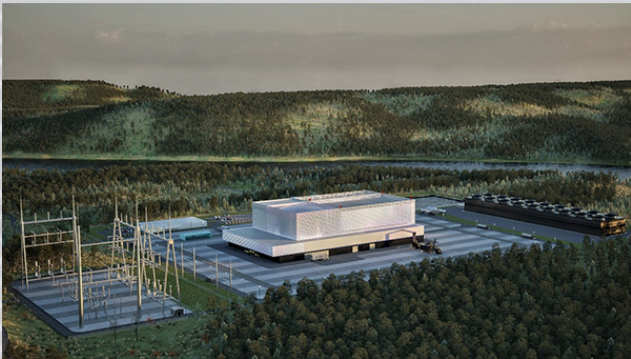

Compact designs generating 300 MWe or less

Advanced Non-LWR

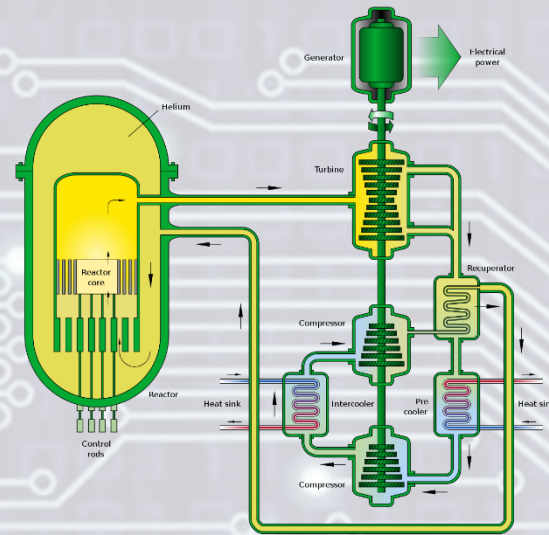

Non-LWR designs ranging from 1 MWe microreactors to several hundred MWe power stations

Selected Characteristics of an Advanced Reactor

- Inherent or passive safety features
- Fewer or no required operator actions
- Minimized the potential for severe accidents and their consequences
- Consideration of security in the design

Adapted from the Commission's [Policy Statement on the Regulation of Advanced Reactors](#).

Data since 2023

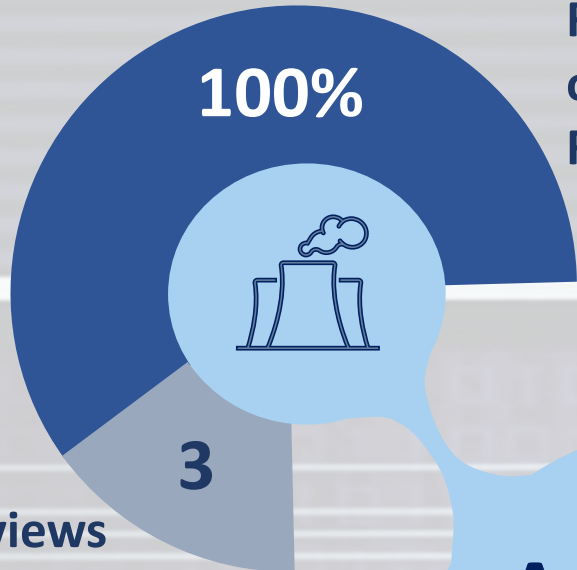

Reviews Completed on Time and Within Resources

Reviews In Progress

Advanced Reactor Execution

Expected Reduction in Construction Resources

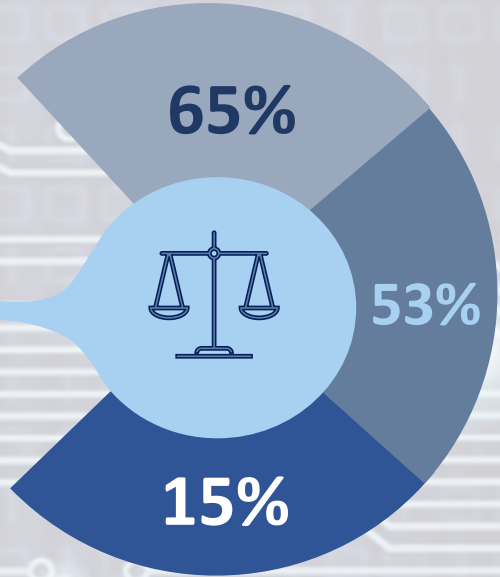

Advanced Reactor Reduced Hourly Rate

Goal of Efficiency Gains from Process Improvements

Average Percentage Under Resource Estimate



Average Percentage Under Schedule Estimate

Average Review Length



Advance Reactors

Kemmerer Unit 1 Construction Permit Application

Kemmerer Unit 1 Safety and Environmental Reviews Complete

Staff review completed in **18 months,**
9 months ahead of schedule and
11% under budget

Streamlined review by
management and ACRS
completed in only 3-months

Streamlined environmental
review resulting in **one-third**
the typical documentation

First fully risk-informed,
performance-based licensing
basis using LMP

FIRST

- Commercial non-LWR in over 40 years
- US Gen-IV commercial sodium fast reactor
- Use of functional containment for commercial power reactor

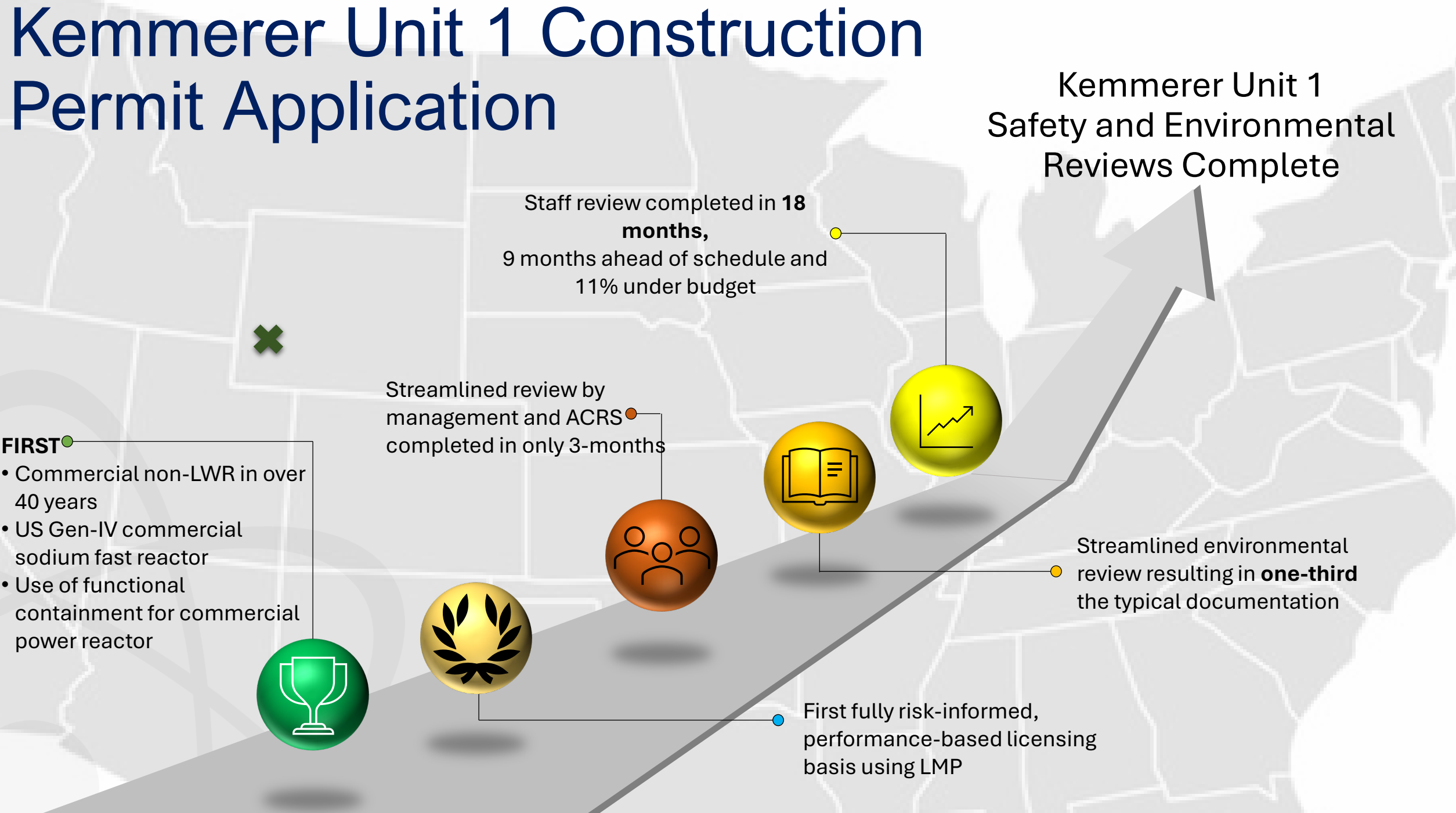
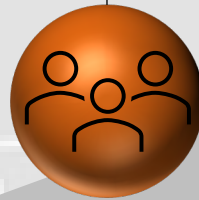

Flexible Reactor Licensing Pathways



10 CFR Part 50

Large majority of operating power reactor and NPUF fleet

Construction Permit + Operating License

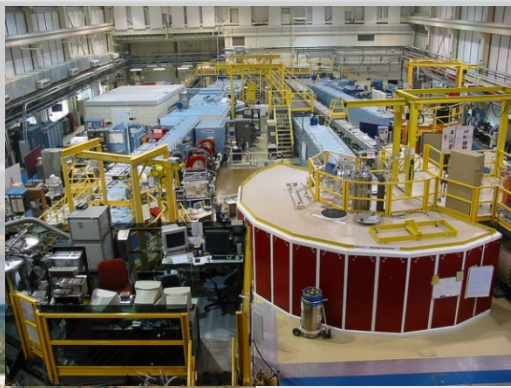

10 CFR Part 52

Vogtle AP-1000, NuScale

Early Site Permit, COL, Design Certification, Manuf. License

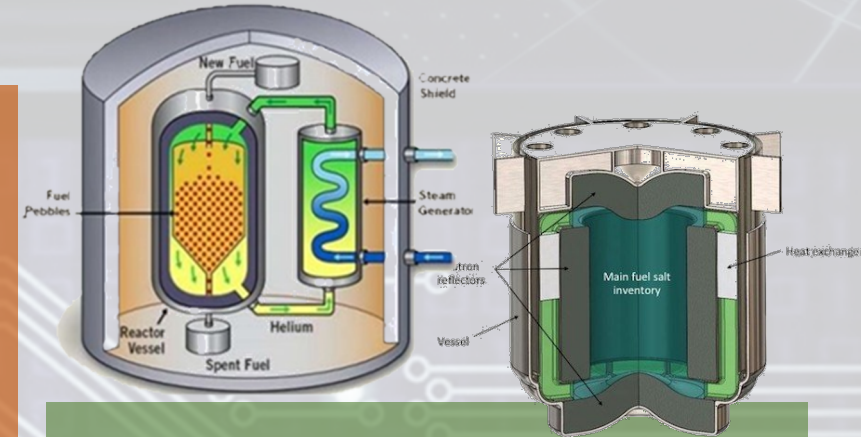

10 CFR Part 53

New licensing framework under development

Technology-inclusive, risk-informed, performance-based framework

Licensing Process with Public Participation

